

BEADBAZOOKA®

Gaither PROFESSIONAL EQUIPMENT

New 2" BEAD BAZOOKA®

Gaither's BB3L2 / BB6L2 / BB10L2

More Power & More Speed



Gaither Tool Company, Inc.
2255 W. Morton Ave
Jacksonville, IL 62650, USA
T 217-245-0545 / 800-452-5010
F 217-245-0940
E sales@gaihertool.com
W www.gaihertool.com

Gaither Europe B.V.
Rechtzaad 6
4703 RC Roosendaal
Netherlands
T +31 165 554475

E pm@gaithereurope.com

Original instructions

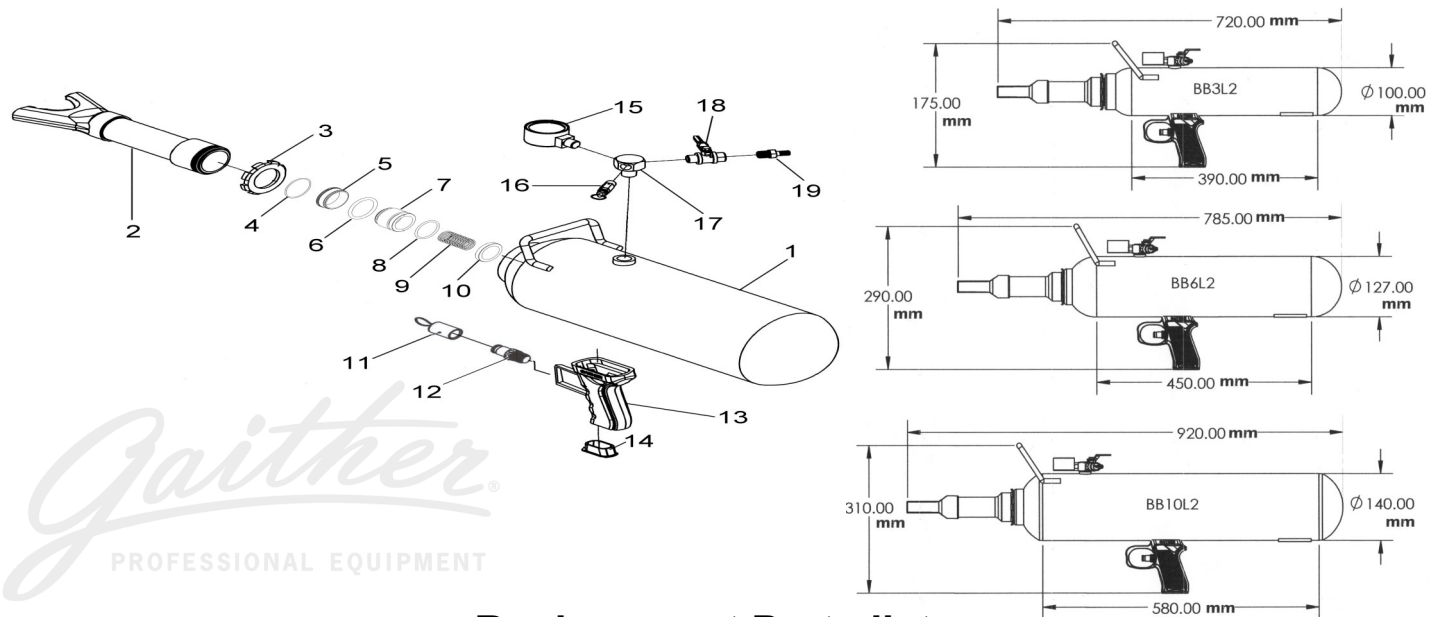

Replacement Parts list

<u>Ref. No.</u>	<u>Part No.</u>	<u>Description</u>
1.	12910B2	Air Tank (3L, 6L, 10L)
2.	12913B2C	Slotted Barrel w/ 2" Connector
3.	12912B2	(50.8 mm) 2" Lock Nut
4.	12950	2" W 1.7 O-Ring
5.	12951	2" Wide Screw
6.	12952	2" W 5.3 O-Ring
7.	12953	2" Piston-L40mm
8.	12954	2" W 3.5 O-Ring
9.	12955	Stainless Spring
10.	12956	2" W 11.2 O-Ring
11.	12919BS	Safety Trigger Caps
12.	12919B	Switch Valve
13.	12920B	Grip-BB
14.	12921B	Plastic Plug
15.	12914B	1.5" Pressure Gauge -10Bar
16.	12917B	CE Safety Valve -Max 10Bar
17.	12930M	F ¼" x3 & M ¼"x1 Connector
18.	12916B	(6.35 mm) ¼"PT Intake Valve
19.	12927	Universal Connector

CAUTION:

- It is best to use clean / filtered compressed air to fill all Bead Bazooka® / Bead Booster® inflation tools.
- Unfiltered or unclean compressed air may result in poor performance and shorten the life of the product.
- Gaither recommends this Bead Bazooka® tank be replaced after 5 years.
- When not using , Please put the Safety Trigger Caps back onto the Switch Valve



Bead Bazooka® Accessories

A.	GB-51	KD-Tire Stand
B.	GB-52	Air-Whip Hose
C.	GB-53	Tire Wedge
D.	GB-54	Safety Pack –goggles & ear plugs
E.	GB-56	Wide Wall Clip w/4 screws



New 2" Bead Bazooka® Repair kit

BBVRK

F.	12958	2" Piston w/ O-Ring
G.	12959	Gaither Wrench
H.	12950	W 1.5 O-Ring



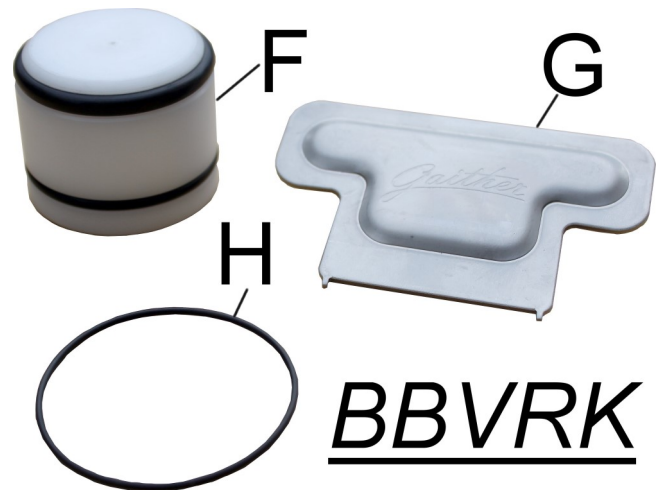



The Bead Bazooka® Valve Repair Kit, or BBVRK, is a new tool that lets the user repair/replace the piston/valve of the Bead Bazooka®. The BBVRK is intended to extend the lifespan of the Bead Bazooka® by making the Bead Bazooka® fully serviceable. This kit saves the user precious time because the repairs can be done quickly and effectively in house.



BBVRK



Replacement Parts list

12916B ¼"PT Intake Valve 	12914B 1.5" Pressure Gauge 	12930M G Connector 
12927 Universal Connector 	12917B CE Safety Valve 	12913B2C Slotted Barrel w/ 2" Connector 



Every Bead Bazooka® includes a wall Clip(GB-56) that can be placed on the work shop wall with simple wood or metal screws: (For safe storage always return the Bead Bazooka® back to its wall clip storage position)



DO NOT PLACE THE BARREL FIRMLY AGAINST THE RIM,

but instead it should be held 2-3" away from the wheel flange when firing for better overall lift and performance

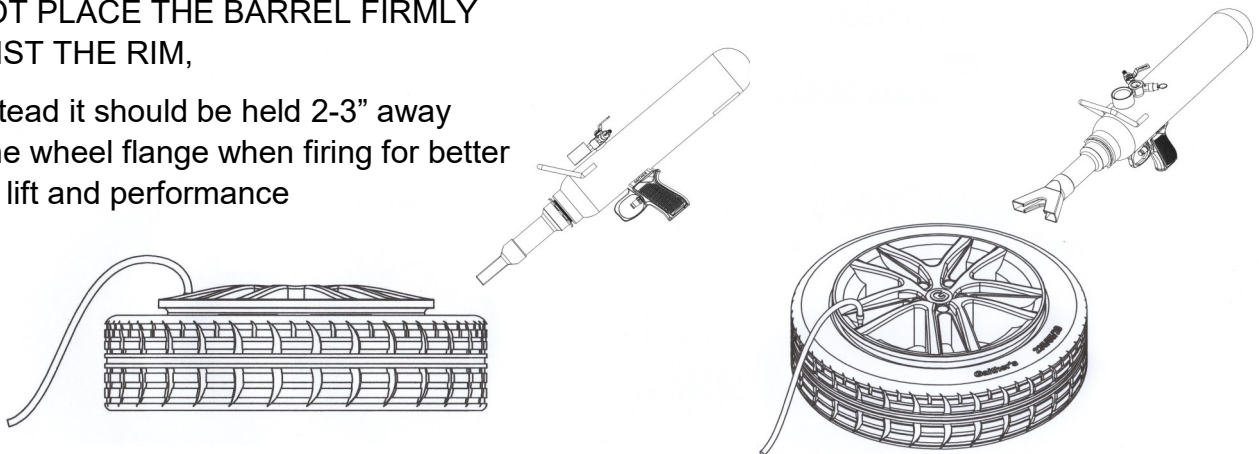

CAUTION:

AFTER THE BEAD HAS BEEN SET TO THE WHEEL, STOP THE AIR FLOW TO THE VALVE STEM, PLACE A VALVE CORE IN THE STEM, AND MOVE THE TIRE / WHEEL ASSEMBLY TO A TIRE INFLATION CAGE AND THEN CONTINUE INFLATING TO THE MANUFACTURER'S RECOMMENDED OPERATING PRESSURE.

WARNING:

COMPRESSED AIR IS DANGEROUS - ALWAYS WEAR EYE AND EAR PROTECTION. ALWAYS FOLLOW THE INSTRUCTIONS GIVEN ABOVE. THE BEAD BAZOOKA® IS A TOOL FOR THE TIRE INDUSTRY AND SHOULD NEVER BE USED OTHERWISE. THIS TOOL IS NOT A GUN. THIS TOOL IS NOT A TOY AND SHOULD NEVER BE USED FOR ANYTHING EXCEPT ITS SPECIFIED USE.

Note:



DO NOT DROP

Drop damage could void your warranty!

For other trouble shooting issues and maintenance suggestions for your new Bead Bazooka®, as well as tips for problematic tires, please log on to www.gaithertool.com

Gaither New 2" Bead Bazooka® Repair kit

BBVRK		
F.	12958	2" Piston-40mm w/ O-Ring
G.	12959	2" Gaither Wrench
H.	12950	2" W 1.7 O-Ring

The Bead Bazooka® Valve Repair Kit, or BBVRK, is a new tool that lets the user repair/replace the piston/valve of the Bead Bazooka®. The BBVRK is intended to extend the lifespan of the Bead Bazooka® by making the Bead Bazooka® fully serviceable. This kit saves the user precious time because the repairs can be done quickly and effectively in house.

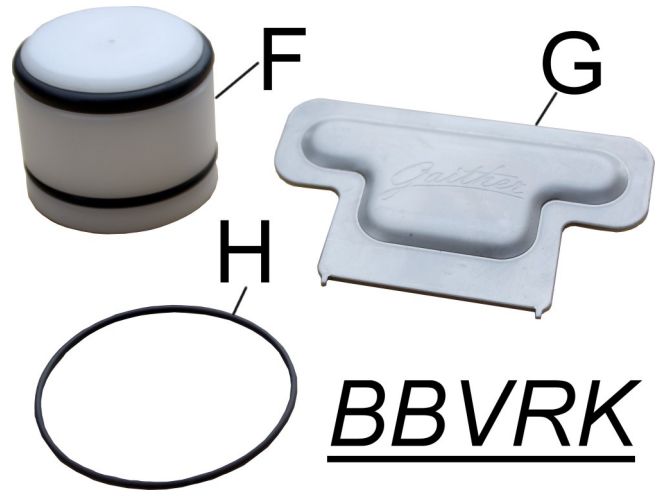

How To Use BBVRK

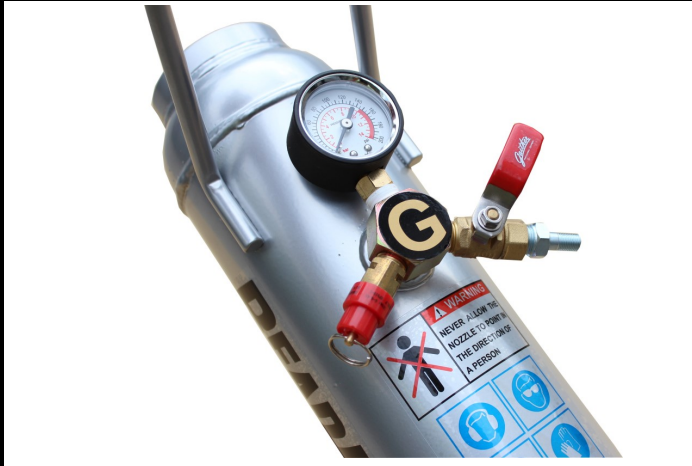

1. Check the Pressure Gauge
No Air - 0 bar. / 0 psi.



2. Bead Bazooka® place the wall clip storage position



3. Use G / Gaither Wrench

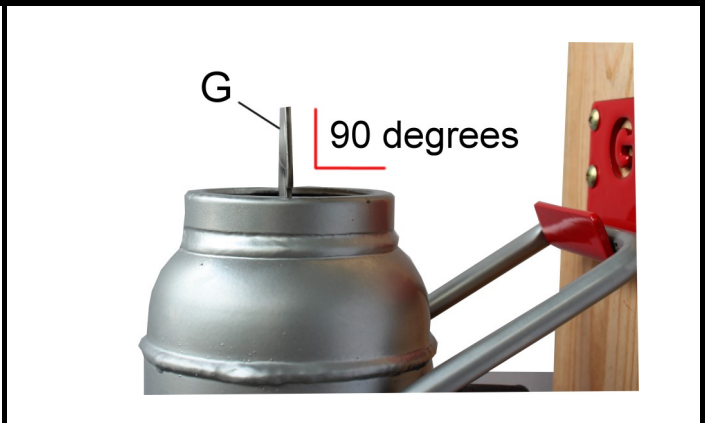

4. Right angle 90 degrees

A



B



Use WD-40
Wait 2~3 minutes

A



B



C



5. Press down with your left hand.

Turn counterclockwise with your right hand



6. Replace F. & H. after opening



Note:

For other trouble shooting issues and maintenance suggestions for your new Bead Bazooka®, as well as tips for problematic tires, please log on to

www.gaithertool.com



Bead Bazooka® Care

For best performance, please add silicone oil or air tool oil to the RAR Valve every 1~2 months by performing the following steps:

- 1.Remove the barrel.
- 2.Push the piston down.
- 3.Apply silicone oil or air tool oil to the upper part of the piston.
- 4.Apply the oil to the edge of the piston. (Black O-Ring)
- 5.Press the piston repeatedly until the oil flow into the interior of valve.



Care and Maintenance :

- Indoor use only
- Avoid this product under the sun or heat exposure
- Often maintenance can increase the time usage of the product
- Use often, please maintenance weekly
- In order to avoid parts damage, do not use this product in the rain
- Recommend using silicone oil for maintaining piston, in order to avoid damage to the parts.

WARNING:

- COMPRESSED AIR IS DANGEROUS - ALWAYS WEAR EYE AND EAR PROTECTION. ALWAYS FOLLOW THE INSTRUCTIONS GIVEN ABOVE.
- THE BEAD BAZOOKA® IS A TOOL FOR THE TIRE INDUSTRY AND SHOULD NEVER BE USED OTHERWISE.
- The product should operate by professionals.
- Never allow the nozzle to point in the direction of a person
- Please vent the rest of air after use.
- Do not try to disassemble or modify the product.
- Please Keep away from children

Repair and Troubleshooting :

- Read the instructions and check BEAD BAZOOKA® to see whether there are missing parts of damaged parts.
- If the Bead Booster can not be used, please contact the store for repair.

BEAD BOOSTER®

gaither PROFESSIONAL EQUIPMENT



#GB-5 (1.5")



#GB-5MA (2")



#12941R (1.5")



#GB-5ZA (1.5")



#GB-38L2 (2")



#12942R (2")

BEAD BAZOOKA®

gaither PROFESSIONAL EQUIPMENT



#BB6L (1.5")



#BB9L (1.5")



#BB12L2 (2")



#BB3L2 (2")



#BB6L2 (2")



#BB10L2 (2")

Set-up of your new Bead Bazooka® (Gaither's BB3L2 / BB6L2/ BB10L2) unit

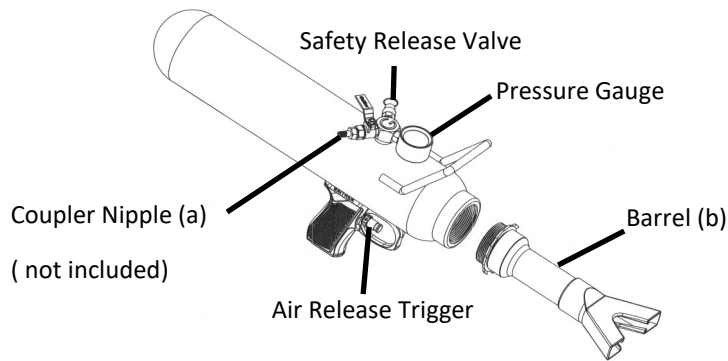

Before using the **Bead Bazooka®** you must install the following:

1) The air coupler nipple is not included. Install an air coupler nipple that fits your particular system into the small intake valve (a) pictured above.

2) The slotted double barrel (b) must be installed into the large release opening shown in the above diagram. Install and secure lock nut so that the slotted double barrel is securely tightened.

Using the Bead Bazooka® with the tire/wheel assembly in a horizontal position:

1. Adjust the slotted double barrel so that the barrel flange is on top (opposite side of the handle stock and trigger release) and parallel to the ground.

2. Place the tire (any size up to medium commercial truck tire) so that the short side of the wheel is on the bottom and the long side of the wheel is on the top. (see diagram #2 below) The valve stem should be pointed upward to the sky. At this point the Gaither tire stand (GB-51) or block of wood should be holding the tire and wheel off the ground and the bottom bead should already be seated properly. (Note: to ensure proper and perfect bead seat, tire and wheel should always be adequately lubricated)

3. Attach an airline to your air coupler nipple and open the intake valve to fill the air tank to the desired working pressure. (see proper storage and unit charging recommendation –next page) **Normal working pressure is from 20 to 150 psi / 1.5 to 10 Bar. The amount of pressure that is needed in the tank depends on the tire size and condition of the tire. The Bead Bazooka® can help set the beads to wheels on motorcycle, passenger, ATV, industrial, truck, and some small agricultural tires.**

4. Using two hands; one on the handle stock with trigger protector and the other on the handle which is on top of the tank, direct the slotted double barrel flange to the wheel exactly opposite the valve stem. (In most cases this is the best position but in some cases with smaller tires it is better to position the barrel close to the valve stem) Once you are in position to fire the Bead Bazooka® you may want to bring the barrel away from the wheel approximately 1" to 2" so that the barrel does not contact the bead as it quickly rises from the force of air flow. Make sure there is no valve core in the valve stem and using an airline or the Gaither Whip Hose (GB-52) apply a steady flow of air into the valve stem while simultaneously firing the Bead Bazooka®. For extreme cases: a Gaither Tire Wedge (GB-53) or wedges may be used under the tire to help close extremely large gaps between tire and wheel. (See Diagram #2)

5. Position the Bead Bazooka® so that the slotted double barrel opening is pointing directly into the largest gap between the tire and wheel. Normally a 50-70 degree angle is the best.

6. Secure tightly the Bead Bazooka® with both hands on both handles and place your index finger onto the trigger. Pull gently to release the air inside of the tank. Hold steady the unit and always keep the air flow directed into the gap between the tire and wheel. Note: If this does not properly set the bead to the wheel, repeat the procedure at a higher pressure. You can also try to use the Bead Bazooka® in an upright position (see next section)

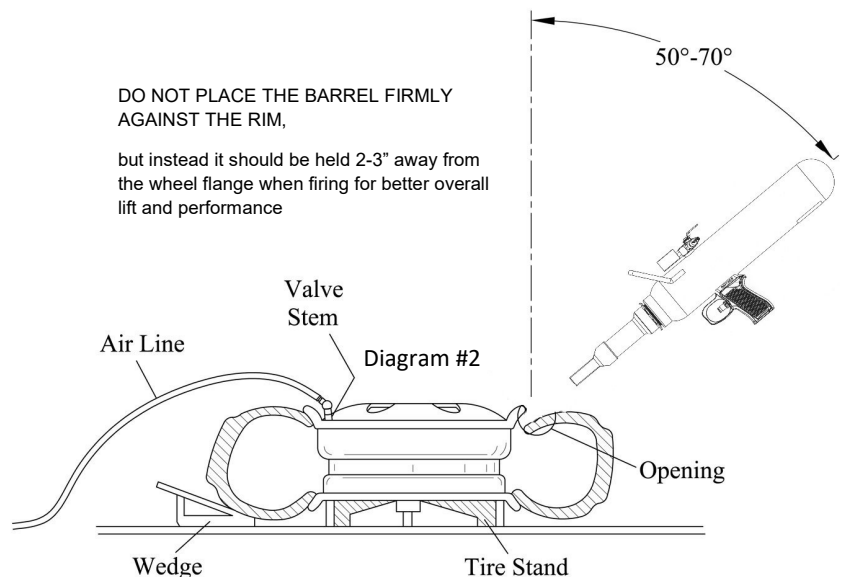

CAUTION: AFTER THE BEAD HAS BEEN SET TO THE WHEEL, STOP THE AIR FLOW TO THE VALVE STEM, PLACE A VALVE CORE IN THE STEM, AND MOVE THE TIRE / WHEEL ASSEMBLY TO A TIRE INFLATION CAGE AND THEN CONTINUE INFLATING TO THE MANUFACTURER'S RECOMMENDED OPERATING PRESSURE.

Using the Bead Bazooka® with the tire/wheel assembly in a vertical position: (recommended for truck tires only)

- 1) Adjust slotted double barrel so that the barrel flange is on the bottom same side as the handle stock with trigger release (opposite side of the pressure gauge) and parallel to the ground. Make sure the barrel is fastened tightly with the lock nut.
- 2) Place tire/wheel assembly against a wall or solid prop so the bottom (or back bead) is already set to the wheel. (see diagram #3) Make sure the valve stem is pointing out and the long side of the wheel is closest to you. The Gaither Tire Wedge (GB-53) can be used as a prop to help set the bead properly.
- 3) Attach an airline to your air coupler nipple and open the intake valve to fill the air tank to the desired working pressure. (see proper storage and unit charging recommendation –next page) **Normal working pressure in the vertical position is from 20 to 150 psi / 1.5 to 10 Bar.** The amount of pressure that is needed in the tank depends on the tire size and condition of the tire.
- 4) Using two hands; one on the handle stock with trigger release and the other on the handle which is on top of the tank, direct the slotted double barrel flange to the wheel exactly opposite the valve stem. Once you are in position to fire the Bead Bazooka® you may want to bring the barrel away from the wheel approximately 1" to 2" so that the barrel does not contact the bead as it quickly rises from the force of air flow. Make sure that there is no valve core in the valve stem and using an airline or the Gaither Whip Hose (GB-52) apply a steady flow of air into the valve stem while simultaneously firing the Bead Bazooka®.
- 5) Position the Bead Bazooka® so that the slotted double barrel opening is pointing directly into the largest gap between the tire and wheel. Normally a 50-70 degree angle is the best.
- 6) Secure tightly the Bead Bazooka® with both hands on both handles and place your index finger onto the trigger. Pull gently to release the air inside of the tank. Hold steady the unit and always keep the air flow directed into the gap between the tire and wheel. Note: If this does not properly set the bead to the wheel, repeat the procedure at a higher pressure.

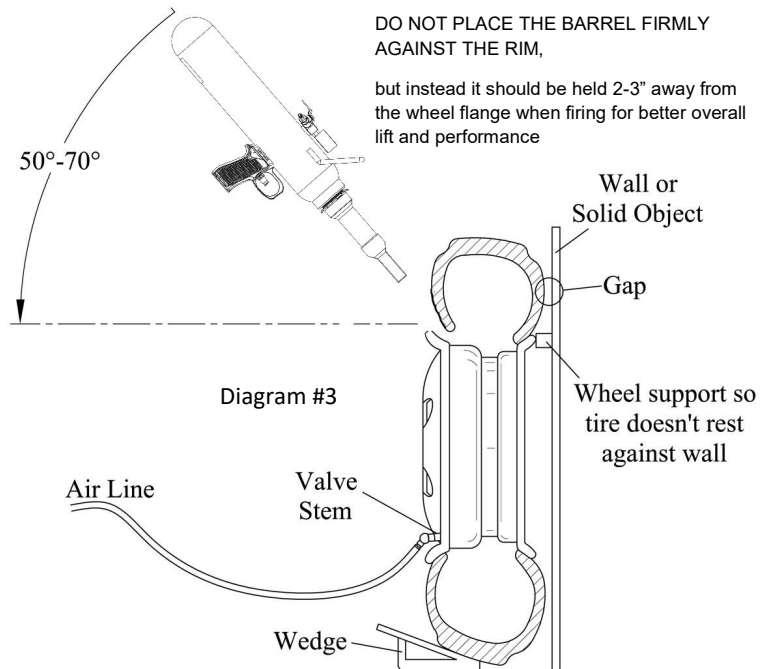

CAUTION: AFTER THE BEAD HAS BEEN SET TO THE WHEEL, STOP THE AIR FLOW TO THE VALVE STEM, PLACE A VALVE CORE IN THE STEM, AND MOVE THE TIRE / WHEEL ASSEMBLY TO A TIRE INFLATION CAGE AND THEN CONTINUE INFLATING TO THE MANUFACTURER'S RECOMMENDED OPERATING PRESSURE.

WARNING: COMPRESSED AIR IS DANGEROUS - ALWAYS WEAR EYE AND EAR PROTECTION. ALWAYS FOLLOW THE INSTRUCTIONS GIVEN ABOVE. THE BEAD BAZOOKA IS A TOOL FOR THE TIRE INDUSTRY AND SHOULD NEVER BE USED OTHERWISE. THIS TOOL IS NOT A GUN. THIS TOOL IS NOT A TOY AND SHOULD NEVER BE USED FOR ANYTHING EXCEPT FOR ITS SPECIFIED USE.

Note: For other trouble shooting issues and maintenance suggestions for your new Bead Bazooka®, as well as tips for problematic tires, please log on to www.gaithertool.com